

MDF Italia interprets the world of contract furniture. From work to hospitality, transversal systems and furnishings are key, capable of enhancing the qualities of each space through design.

book1 Indoor

book2 Outdoor

book3 Contract

mdf italia

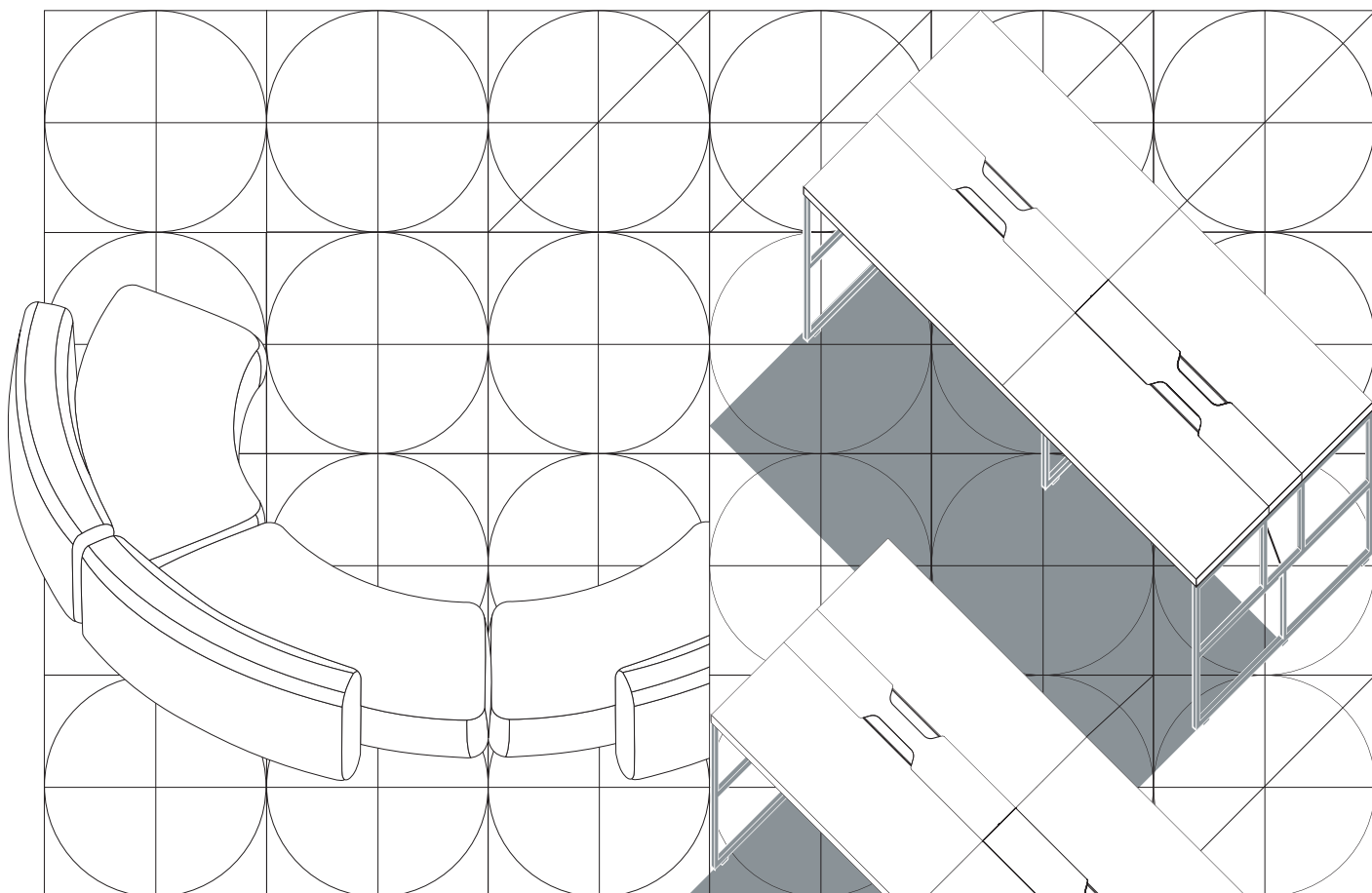

Contract book

Contract Index	Office	Hospitality
Contract	2 Reception	10 Lobby 68
Products collection	4 Open Space	14 Restaurant and Café 78
	Executive Office	24 Hallway 92
References	110 Meeting Room	32 Superior Guestroom 96
Tools and awards	117 Informal Area	40 Executive Suite 100
967arch	118 Lounge Café	44 Rooftop 104
	Conference Room	54
	Outdoor	60



see also the
other mdf italia
printed volumes

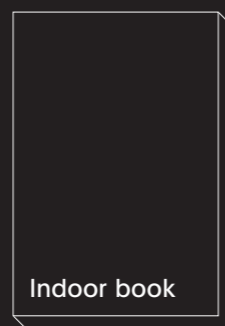

Indoor book

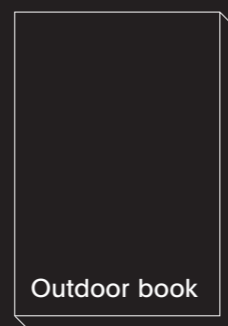

Outdoor book

Contract book

Office+Hospitality

mdf italia

^{EN} Pioneers in a new way of conceiving space, we focus on the uniqueness of each place, whether it is dedicated to work or hospitality. Through analysis and stories, the Contract book supports the developed projects with two suggestions designed by 967arch, architectural firm in Milan. A link between ideas and reality, these examples show the cross-cutting nature of our products and the strong aesthetics common to all.

^{IT} Pionieri di un nuovo modo di concepire lo spazio, mettiamo al centro della nostra riflessione l'unicità di ogni luogo, anche di lavoro o dedicato all'ospitalità. Tra analisi e racconto, nel Contract book affianchiamo ai progetti realizzati due proposte firmate dallo studio di architettura milanese 967arch. Trait d'union fra idee e realtà, queste proposte dimostrano la trasversalità dei nostri prodotti e il forte carattere estetico che li accomuna.

Sofas, armchairs, pouf and beds

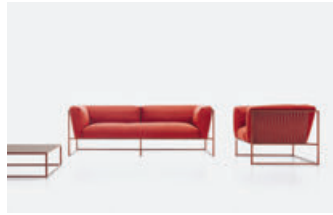

Arpa collection



Neil armchair



Achille armchair



Neil Twist chair



Cosy



Neil Twist armchair



Aïku Soft chair



Universal chair



Cosy Curve



Fuji

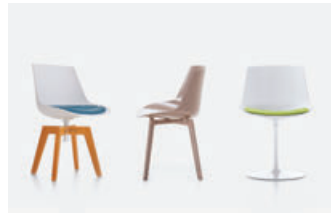

Flow Chair

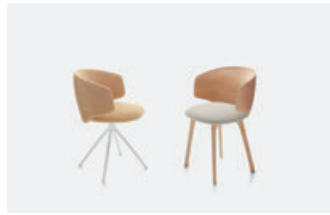

Universal armchair



Cosy Island



Aluminium bed



Flow Slim



Sag



Mia sofa and armchair



Cosy bed



Neil Leather chair



Sign Matt



Yale X sofa and armchair



Neil Textile chair



Neil stool collection

Furniture, systems and complements



Divide IT

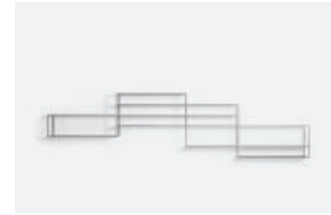

Minima 3.0 Sketch

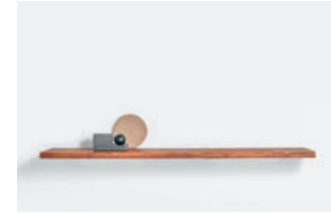

Link 1



Minima 3.0 Sideboard



Mamba Light



Random



Minima 3.0



Random Box



Minima 3.0 Room Divider

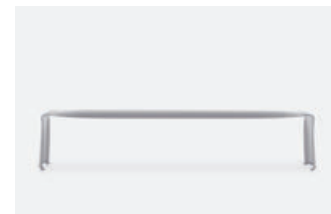

Le Banc



Offset



Axy



La Grande Table



NVL Table



Rock Table



Tense collection



20.Venti system



20. Venti Light



20. Venti Home Light



Flow Low Table



La Table Basse



Metodo



Yale Low Table

EN The concept of offices is changing. Fixed workstations are making way for a new means of nomadic, smart production, and working spaces are becoming inviting, immersive places to meet. Workers move quickly from one workstation to the other, laptop in hand. They are looking to share, but also for some privacy; interaction, but also concentration. More formal rituals are evolving in light of technological innovations, such as standing meetings or conference tables with devices for remote calls. Accustomed to working from home, we now require new levels of comfort at the workplace. No discipline interprets these changes more than design while also reflecting such contemporary cultural changes. This is why MDF Italia uses design to meet the needs of working spaces in an innovative way.

IT Il concetto di ufficio sta cambiando: le postazioni fisse lasciano il campo a nuove modalità di produzione nomade e smart, e gli spazi di lavoro diventano ambienti d'incontro, ospitali e immersivi. Ci si sposta con rapidità da una workstation all'altra, laptop alla mano. Si cerca la condivisione, ma anche la privacy; il dialogo, ma anche la concentrazione. Le ritualità più formali evolvono alla luce delle innovazioni tecnologiche, come nel caso degli standing meeting o dei tavoli da riunione dotati di dispositivi per le call a distanza. Abituati al lavoro da casa, chiediamo ai luoghi di lavoro nuovi livelli di comfort. Nessuna disciplina più del design è interprete di questi cambiamenti e rispecchia altrettanto bene le evoluzioni culturali contemporanee. Per questo MDF Italia usa proprio il design per dare una risposta innovativa alle esigenze degli spazi di lavoro.

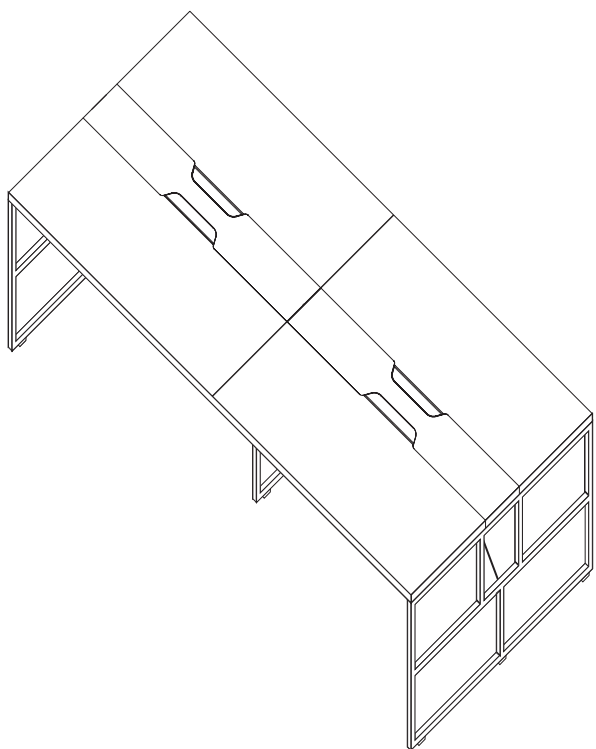

R

Reception

OS

Open Space

EO

Executive Office

MR

Meeting Room

IA

Informal Area

LC

Lounge Café

CR

Conference Room

O

Outdoor

The first space we find when entering a workplace is reception. Situated at the entrance, it invites people crossing it and those stopping for a longer time to feel welcome and at ease. Padded elements, seating, and accessories create dynamic, elegant furnishings with a mark of comfort and hospitality.

Il primo spazio che s'incontra entrando in un luogo di lavoro è la reception. Posta all'ingresso, invita sia chi la attraversa sia chi vi sosta più a lungo a sentirsi accolto e a proprio agio. Imbottiti, sedute e complementi consentono di arredarla in modo dinamico ed elegante, all'insegna del comfort e dell'ospitalità.

R

Reception



OS

EO

MR

IA

LC

CR

O



Divide IT

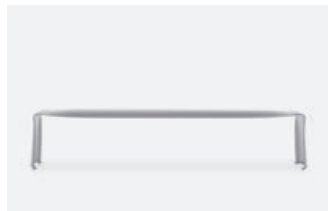

Le Banc



Yale X



Neil armchair



Yale Low Table



Variety and balance, functionality and flexibility. To rationalize a dynamic, sometimes complex space such as today's open spaces, modular workstations, lounge areas, intermediate operational spaces, and discretionary islands are necessary, created using tables, seating, and bookcases by MDF Italia.

Pluralità ed equilibrio, funzionalità e flessibilità. Per rendere razionale uno spazio dinamico, a volte complesso, come l'open space contemporaneo, c'è bisogno di postazioni di lavoro modulari, aree lounge, spazi operativi intermedi e isole discrezionali, create usando tavoli, sedute e librerie di MDF Italia.

^R
OS
 Open Space

EO

MR

IA

LC

CR

O



20.Venti Light high table



Neil Leather stool



Random



Neil Textile chair



Tense collection



Minima 3.0 Room Divider



20.Venti Light



20.Venti Light



Fuji

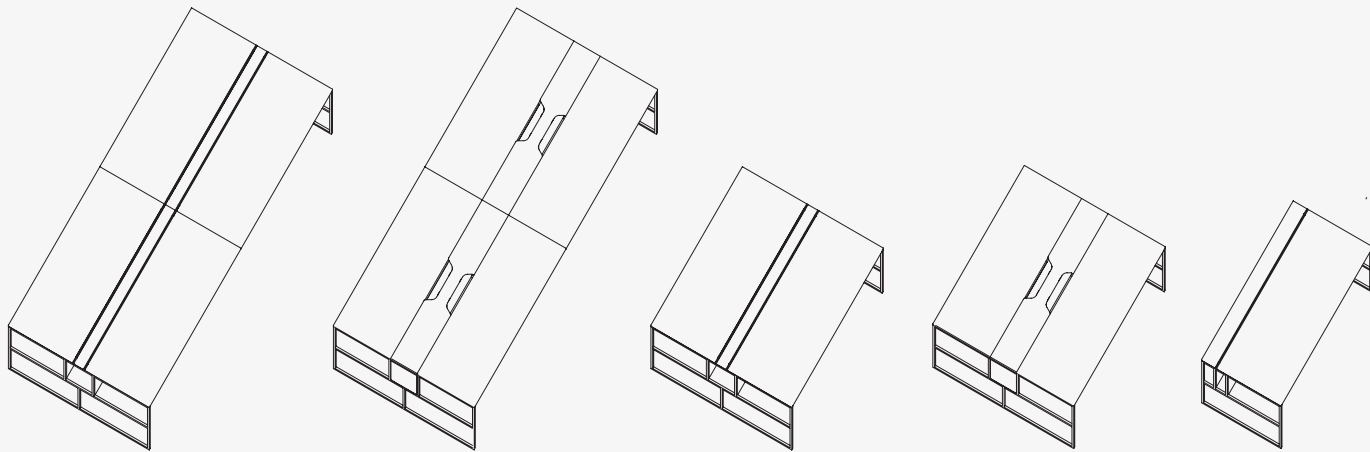

20.Venti system

Designed by 967arch

Un profilo 20×20 genera il frame del telaio, un segno che si integra alla perfezione con le collezioni di tavoli e contenimento di MDF Italia.

A slender frame generated by a 20×20 profile, a feature that perfectly merges with MDF Italia table and storage collections.



EN 20.Venti is an office system with a linear, iconic, versatile design created by 967arch. With a light structure, a contrast between full and empty, and quality materials and finishes, this is a contemporary interpretation of the desk, the archetypical workstation. Available in a wide range of sizes and colours, 20.Venti includes individual tables, double and quadruple workstations, a high workstation, and flexible combinations designed to adapt to spaces and the teams that use them. Combined with various accessories, 20.Venti allows to create a welcoming, functional space for working agilely and productively. In 2020, 20.Venti was selected for the 26th ADI Compasso d'Oro.

IT 20.Venti è un sistema per l'ufficio dal design lineare, iconico e versatile, disegnato da 967arch. Caratterizzato dalla struttura leggera, dalla contrapposizione tra pieni e vuoti e dalla qualità dei materiali e delle finiture, è una rivisitazione in chiave contemporanea dello scrittoio, archetipo della postazione di lavoro. Disponibile in un'ampia varietà di misure e varianti cromatiche, 20.Venti comprende tavoli singoli, postazioni doppie e quadruple, una workstation alta e alcune combinazioni flessibili, nate per adattarsi agli spazi e ai team di lavoro che le useranno. Abbinabile a diversi accessori, 20.Venti consente di creare uno spazio accogliente e funzionale in cui lavorare in modo agile e produttivo. Nel 2020, 20.Venti è stato selezionato per il XXVI Compasso d'Oro dell'ADI.

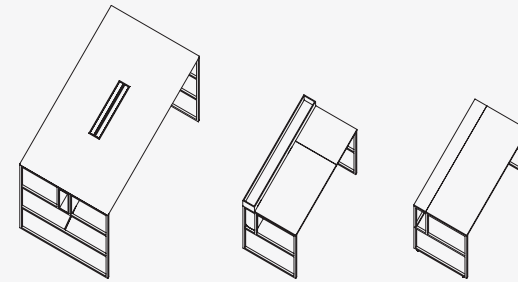

Schermo fonoassorbente, pannello con imbottitura interna in poliesteri a densità variabile brevettato Snow-sound Technology, rivestimento esterno in tessuto di poliestere Trevira CS.

Sound-absorption screen, panel with variable density internal padding patented by Snowsound Technology, external polyester fabric cover Trevira CS.

Selected for Compasso D'Oro ADI 2020

Discover 20.Venti collection

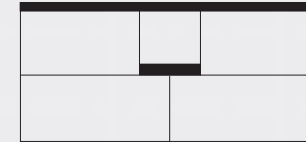



Flow Low Table

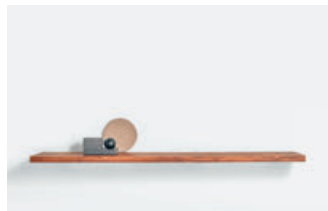

Link 1

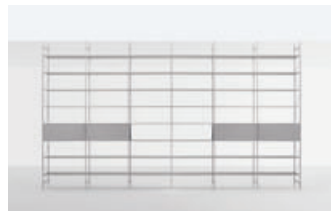

Minima 3.0 Room Divider



20.Venti system



Mia sofa and armchair



A space suitable for formal and managerial activities, but also more intimate moments. In the executive office, which houses operational stations and cosier areas for interaction and privacy, MDF Italia reinterprets the experience acquired in domestic environments in light of the technical and regulatory requirements for working spaces.

Uno spazio idoneo ad attività di rappresentanza e management, ma anche a momenti più intimi. Nell'executive office, che ospita postazioni operative e zone più raccolte dedicate al dialogo e alla privacy, MDF Italia rilegge l'esperienza maturata in ambito domestico alla luce delle soluzioni tecniche e normative richieste dagli spazi di lavoro.

R

OS
EO
 Executive Office

MR

IA

LC

CR

O



Metodo



Flow Slim



Axy



Cosy

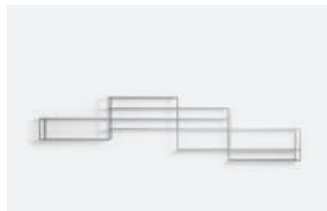

Minima 3.0 Sketch



Flow Chair

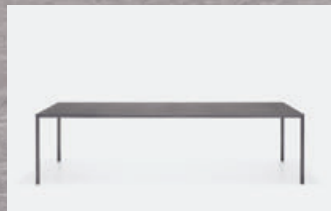

Tense collection

FOCUS ON



Flow collection

Designed by Jean Marie Massaud

Shell



Shell colors

Chair

L53 D54.5 H80.5 cm

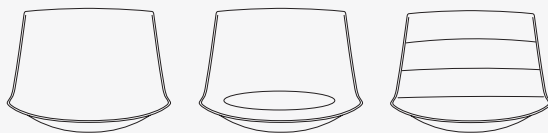

Slim

L55 D53 H76.4 cm



Textile and Leather

L54 D55.5 H80.5 / L56 D54 H76.4 cm

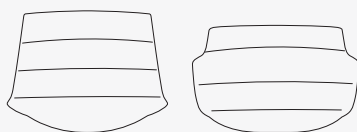

Filo

L53.2 D55.6 H80.5 / L56.8 D55.6 H76.5 cm

Pad

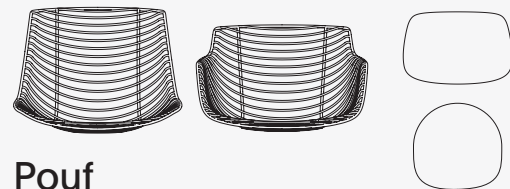

Stool

L52 D48 H44 / H65 / H78 cm



Pouf

L56 D56 / L54 D54 / H48 cm



EN Developed in 2009 from an idea by Jean Marie Massaud, Flow Chair is a versatile, flexible chair that has evolved over time into a family of products capable of meeting every need and style. The curves and elegance of the profile create a perfect blend of comfort and ergonomics. With different bases and a wide range of finishes, Flow integrates into the most varied contexts without ever betraying its original character. In 2014, the Flow line was enriched with the Slim variation, a small armchair with sinuous lines and a contemporary character. Like the original chair, it fits in harmoniously with any environment.

IT Nata nel 2009 da un'idea di Jean Marie Massaud, Flow Chair è una seduta versatile e flessibile, che nel tempo si è evoluta in una famiglia di prodotti in grado di soddisfare ogni esigenza e stile. Le linee curve e l'eleganza del profilo si combinano in un'alchimia perfetta di comfort ed ergonomia. Grazie a diversi basamenti e un'ampia gamma di finiture, Flow si integra nei contesti più diversi, senza mai tradire il suo carattere originale. Nel 2014, la linea Flow si è arricchita della variante Slim, una poltroncina dalle linee sinuose e dal carattere contemporaneo, che come la seduta originale si integra armoniosamente in qualsiasi ambiente.

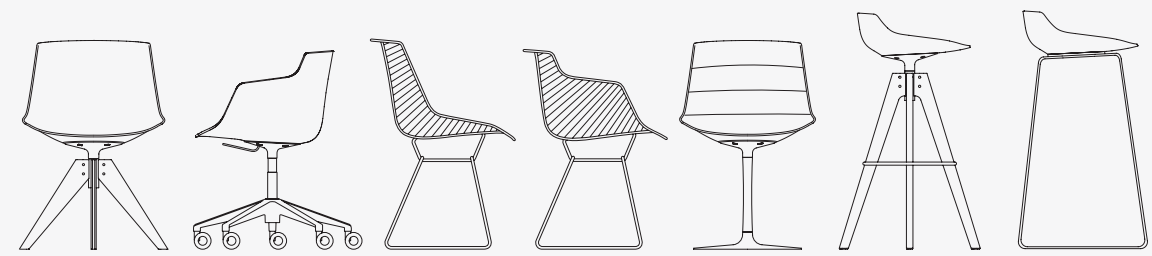

8 bases, 10 shells, 4 colours, 250 fabrics,
more than 100.000 configurations.
Create yours!

Discover
Flow
collection



Base

VN4LS

VN 4 legged steel

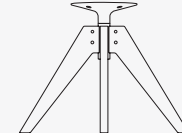

VN4LO

VN 4 legged oak



4LO

4 Legged oak

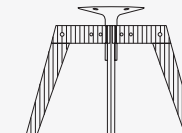

4LI

4 Legged Iroko

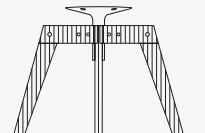

CL

Central leg

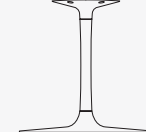

5PSC

5 point star on castors

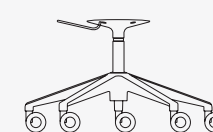

4LC

4 Legged cross

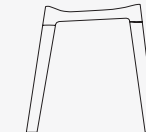

4LOC

4 Legged oak cross

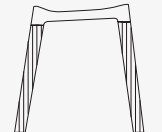



Una collezione ampia e versatile per rispondere alle diverse esigenze di mercato.

A complete and versatile collection to meet different market needs.

Le linee curve della seduta e l'eleganza del profilo si combinano in un'alchimia perfetta garantendo comfort ed ergonomia.

A curved seat and elegant profile blend in perfect harmony to ensure comfort and ergonomics alike.





A place dedicated to meeting, interaction, and sharing ideas, as functional as it is symbolic. The MDF Italia conference room is essential and calibrated. The few essential furnishings enhance the aesthetics and formal quality of a space where ideas and people are the main features.

Un luogo dedicato all'incontro, al confronto e alla condivisione di idee, funzionale tanto quanto simbolico. La sala riunioni di MDF Italia è essenziale e calibrata: i pochi arredi necessari valorizzano le qualità estetiche e formali di uno spazio dove a essere protagonisti sono le idee e le persone.

MR
Meeting Room



Neil Leather chair



Tense collection



Minima 3.0 Sideboard



FOCUS ON



EN Designed in 2009 by Piergiorgio and Michele Cazzaniga, Tense represents the core idea of a table, so authentic and minimal that it adapts to the most varied environments, whether residential or professional. The extreme consistency of shapes and finishes, single, identical materials for the legs and top, transmits a feeling of lightness and stability, compactness and contemporary style. With a technological heart enclosed in the panel in the top, the table can reach up to 4 metres in length. Today, Tense is a system of tables defined through different materials, colours, and heights to meet any need.

IT Progettato nel 2009 da Piergiorgio e Michele Cazzaniga, Tense rappresenta il nucleo dell'idea di tavolo, talmente autentico e minimale da adattarsi agli ambienti più svariati, sia residenziali che contract. La coerenza estrema di forme e finiture, monomateriche e identiche per gambe e top, veicola una sensazione di leggerezza e stabilità, compattezza e contemporaneità. Grazie a un cuore tecnologico, racchiuso nel pannello del piano, il tavolo può raggiungere sino a 4 metri di lunghezza. Oggi Tense è un sistema di tavoli che si articola in diversi materiali, colori e altezze, per rispondere a qualsiasi esigenza di utilizzo.

Tense collection

Designed by Piergiorgio & Michele Cazzaniga

I tavoli sono disponibili anche nella versione attrezzata con 1 o 2 top-access e vaschetta portacavi sotto top.

The tables are also available in the version equipped with 1 or 2 top-access and under top cable tray.

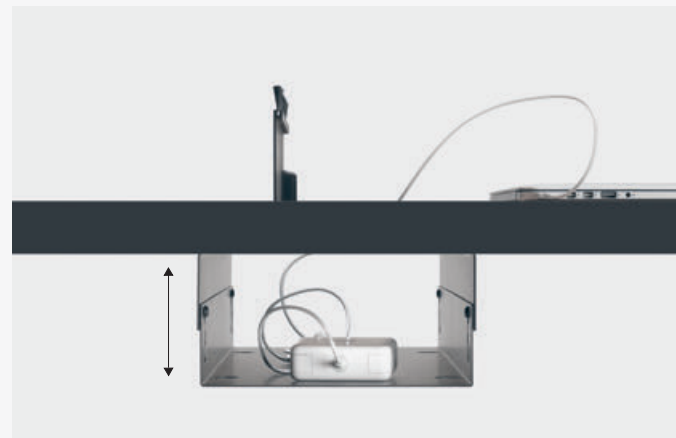

Meeting Room



Office



XXII
Compasso d'Oro
ADI, Special Mention

Discover
Tense
collection



5 heights, 16 finishes, 31 sizes, 1 thickness,
over 1200 combinations.
Configure yours!

Bar high table	H 110
High table	H 90
Working and dining table	H 73
Coffee table	H 45
Low table	H 35

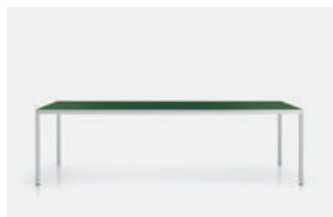

Offset



Universal armchair



Minima 3.0

The concept of working space/time has increasingly blurred boundaries, integrating aspects such as relaxation, leisure, short breaks, and informal interaction. The quality of these moments is directly proportional to the quality of the environment where they take place, which is being continuously reworked following suggestions from home.

Il concetto di tempo-spazio lavorativo assume contorni sempre più sfumati, integrando aspetti come il relax, lo svago, la pausa breve, l'incontro informale. La qualità di questi momenti è direttamente proporzionale alla qualità dell'ambiente in cui si svolgono, che sempre più spesso si rifà a suggestioni domestiche.

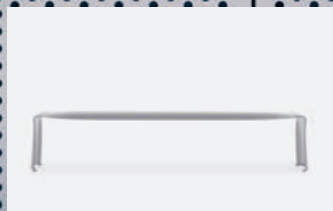

Le Banc



La Table Basse



Neil Twist armchair



R

OS

EO

MR

LC

CR

O



Minima 3.0 Sideboard



Mia armchair



Sign Matt armchair



Fuji



Sag



In its original meaning, the word 'restoration' included the expression 'renew oneself', which well defines the need of workers to rebuild, or better yet, regenerate, themselves. In the world of offices, the coffee bar and refreshment areas in general become satisfying places between comfort and design.

La parola 'ristoro', nella sua accezione originaria, comprende l'espressione 'rimettersi a nuovo' che ben definisce il bisogno di chi lavora di ricostruirsi, o meglio, di rigenerarsi. Nel contesto del mondo ufficio, la caffetteria e più in generale le aree dedicate al ristoro diventano luoghi appaganti, tra comfort e design.

R

OS

EO

MR

IA

LC
Lounge Café

CR

O



Rock Table



Neil Twist chair



Cosy Curve



Flow Low Table



Fuji



Neil Twist stool



Rock Table



Flow Low Table



Fuji



Cosy Curve



Cosy Island

FOCUS ON

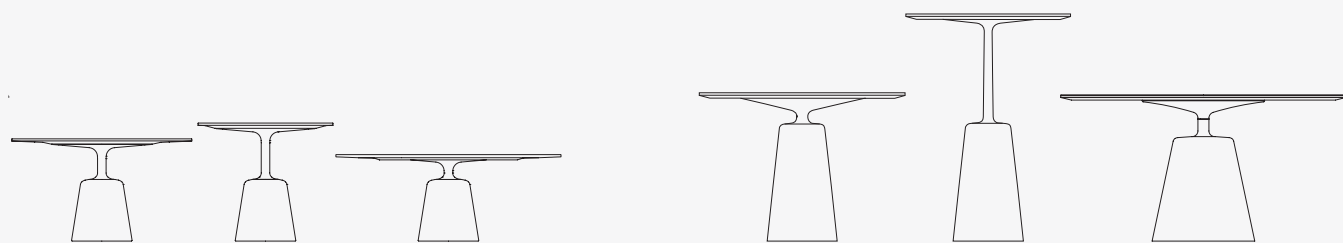
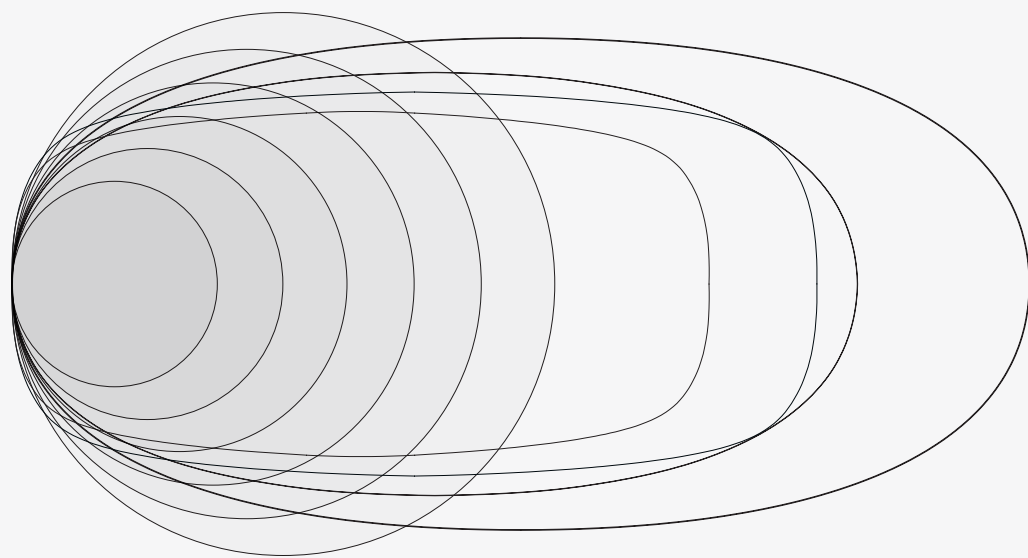

EN Designed by Jean Marie Massaud, Rock Table is a 'round table' that seems to float above a solid, inorganic base. A refined, solid object, light and stable, radical and sensual, it is obtained through a mix of natural and industrial materials. The soft, iconic design based on essential shapes is combined with innovative production systems that make Rock Table suitable not only to living areas and modern living rooms, but also working areas such as offices and conference rooms, indoors and outdoors. Available in various sizes and finishes, even an oval variation, Rock Table opens a direct relationship among people sitting around the table, facilitating interaction and communication.

IT Disegnata da Jean Marie Massaud, Rock Table è una "tavola rotonda" che sembra levitare su una solida base inorganica. Un oggetto raffinato e solido, leggero e stabile, radicale e sensuale, è ottenuta grazie a una miscela di materiali naturali e industriali. Il design morbido e iconico, basato sulla semplificazione delle forme, si combina con sistemi di produzione innovativi che rendono i Rock Table adatti non solo ad aree living e soggiorni moderni ma anche a contesti lavorativi come uffici e sale riunioni, indoor e outdoor. Disponibile in diverse dimensioni e finiture, anche in una variante ovale, Rock Table consente un rapporto diretto tra chi siede attorno al tavolo, facilitando l'interazione e il dialogo.

Rock Table collection

Designed by Jean Marie Massaud

Rock Table è disponibile nella versione rotonda in tre diverse altezze, nella variante ovale con due basamenti a sostegno del top, e con piano rettangolare con angoli smussati.

Rock Table is available in a round version in three different heights, in an oval version with two bases supporting the top, and with a rectangular top with rounded corners.

Rock Table Maxi si presenta con un top in legno in tre finiture, oltre che nelle versioni in cemento, cemento granigliato e laccate.

Rock Table Maxi comes with a wooden top in three finishes, as well as in cement, stone-chip cement and lacquered versions.



Cement and stone-chip concrete finishes are transversal to both indoor and outdoor environments.

Discover
Rock Table
collection



FOCUS ON

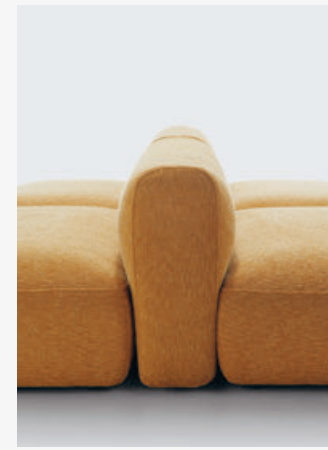

EN Designed by Francesco Rota, Cosy is a family of padded, modular elements capable of offering great comfort in different settings. Featuring modules and compositional freedom, it interacts with any context due to seating of different depths and lengths, backrests of different heights, small tables, accessories, and additional cushions. Cosy is also available in the Island version, with island elements that allow it to turn into a sofa for the middle of the room, and the Curve version, featuring a curved base and backrest, designed to become the natural focus for developing fluid spaces in modern homes or large open spaces in offices and hospitality locations.

IT Progettata da Francesco Rota, Cosy è una famiglia di imbottiti ad elementi componibili capaci di offrire grande comfort in ambienti differenti. Caratterizzata da modularità e libertà compositiva, è in grado di dialogare con qualsiasi contesto grazie a sedute di differenti profondità e lunghezze, schienali ad altezze diverse, tavolini, accessori e cuscini aggiuntivi. Cosy è disponibile anche nella versione Island, dotata di elementi a isola che le permettono di trasformarsi in un divano da centro stanza, e nella versione Curve, caratterizzata da basamento e schienale curvi, pensata per diventare il naturale baricentro attorno cui si sviluppano gli spazi fluidi della casa moderna o i grandi open space del mondo office e hospitality.



Cosy Island & Curve

Designed by Francesco Rota

I moduli a isola e curvi possono essere combinati tra di loro per dare vita a infinite configurazioni.

Island and curved modules can be combined to create infinite configurations.

Cosy è un sistema di divani caratterizzato da un design avvolgente e da grandi e morbide cuscinate.

Cosy is a sofa system with an enveloping design and large, soft cushions.

More than 170 fabrics available.

Discover Cosy collection

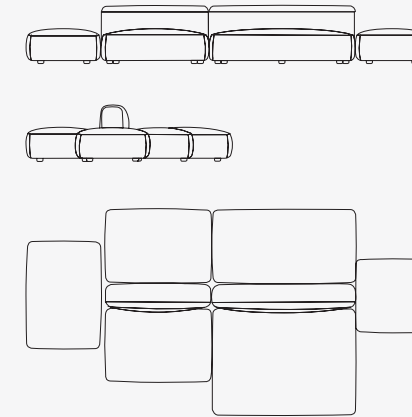
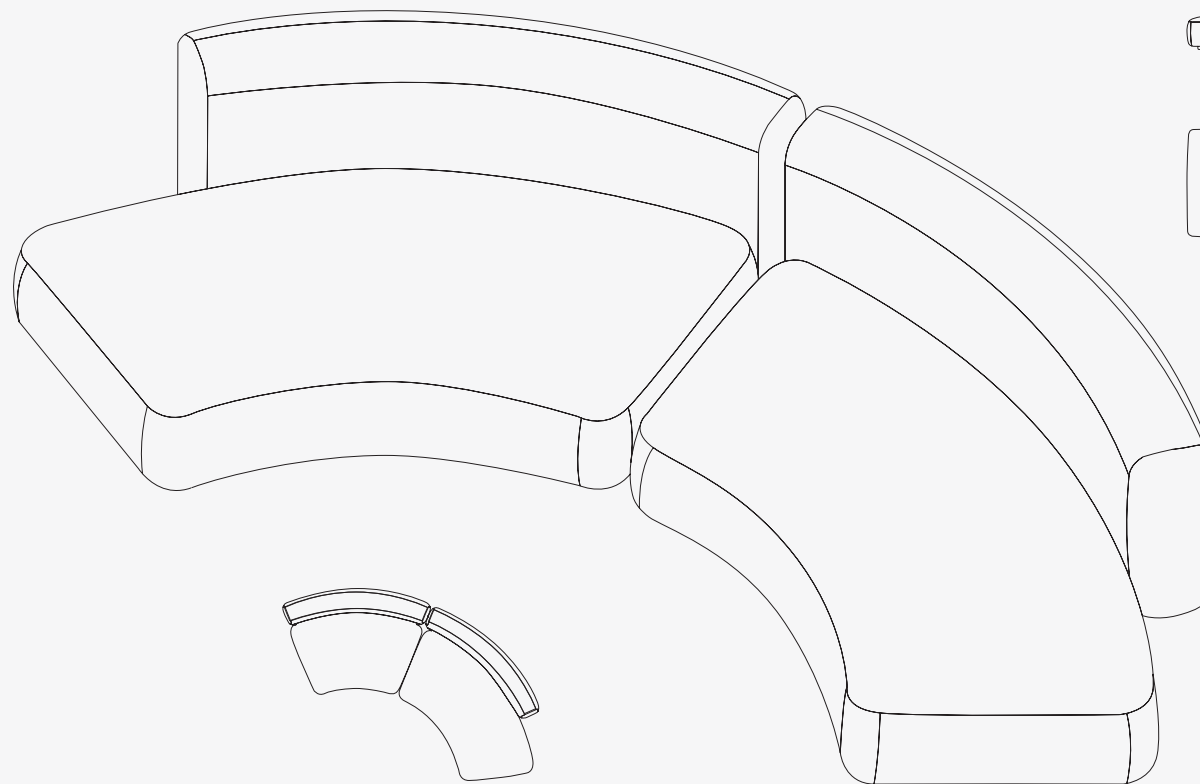
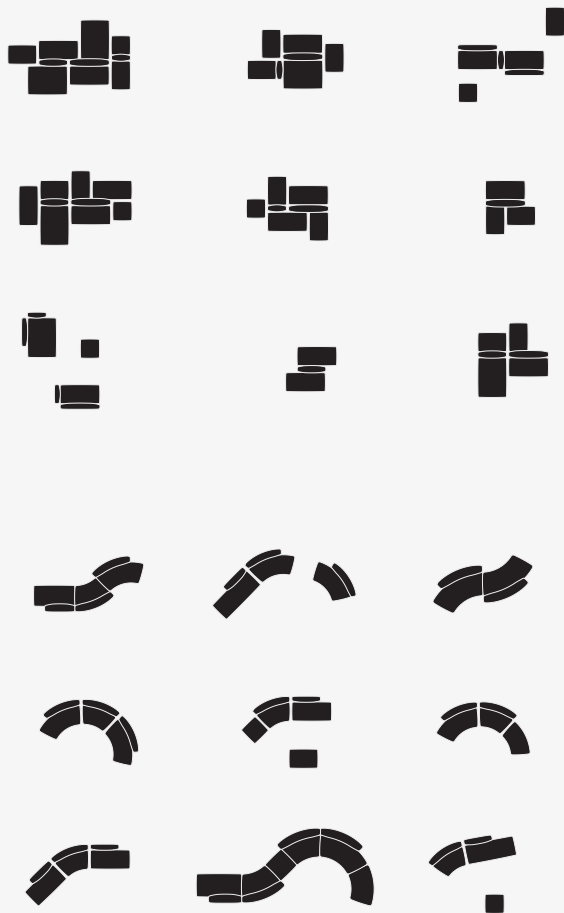



The auditorium meets the need to conduct training activities within the working space. It is a flexible place where the configuration of the furniture should be dynamic, and the products tested for this particular type of use.

L'auditorium risponde all'esigenza di svolgere attività di formazione all'interno dello spazio di lavoro. È un luogo flessibile, dove la configurazione degli arredi dev'essere dinamica, e i prodotti testati per questa particolare tipologia d'uso.

R

OS

EO

MR

IA

LC

CR
Conference Room

O



Achille armchair



La Grande Table



Aïku Soft chair

FOCUS ON

EN Aïku is a seating collection designed by Jean Marie Massaud for domestic environments and professional contract spaces. The name derives from the Japanese term 'haiku', that is, a poetic composition that requires great synthesis of thought and image due to its extreme conciseness. The same is true of Aïku, an object that reconciles the radical nature of the concept and a refined architecture designed to adapt to any environment thanks to a wide variety of finishes and materials for the base and body. Also available in the Soft version, with a padded shell, and Stool, an elegant and cool stackable stool.

IT Aïku è una collezione di sedute progettata da Jean Marie Massaud per l'ambito domestico e gli spazi contract. Il nome deriva dal termine giapponese haiku, che indica un componimento poetico che per l'estrema brevità richiede una grande sintesi di pensiero e d'immagine. Lo stesso vale per Aïku, un oggetto che concilia la radicalità del concept e una raffinata architettura pensata per adattarsi a qualsiasi ambiente, grazie a una grande varietà di finiture e materiali per il basamento e la scocca. Disponibile anche nella versione Soft, con scocca imbottita, e Stool, uno sgabello, impilabile ed elegante.

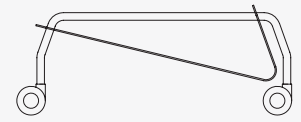
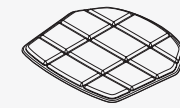
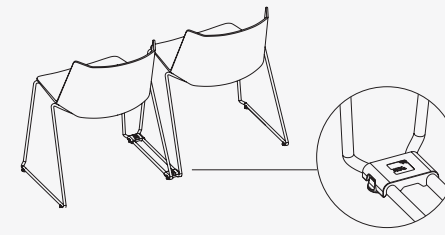

Aïku collection

Designed by Jean Marie Massaud

Una seduta versatile che incontra le diverse necessità del mondo contract.

A versatile seat that meets the diverse needs of the contract market.

Pad imbottito opzionale per aggiungere comfort alla seduta.

Optional padded pad to add comfort to the seat.

Easily stackable up to 15 units.

Discover Aïku Collection





The architecture of working spaces increasingly meets the need to fuse indoors and outdoors, creating outdoor or semi-outdoor areas where activities usually designated for closed spaces can be carried out. From meetings to breaks, outdoor areas are important spaces enhanced with seating, tables, and innovative, long-lasting furnishings.

L'architettura degli spazi di lavoro si confronta sempre più spesso con l'esigenza di relazionare l'interno con l'esterno, creando aree outdoor o semi-outdoor in cui poter svolgere attività abitualmente destinate agli spazi chiusi. Dall'incontro alla pausa, l'area outdoor è uno spazio qualificante, valorizzato da sedute, tavoli e complementi innovativi e durevoli.

R

OS

EO

MR

IA

LC

CR



Arpa



Arpa armchair



Arpa low table

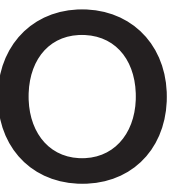

Outdoor



EN Hospitality is a question of context and atmosphere, two concepts that we have long explored in domestic environments and which we now translate for contracts. Restaurants, cafés, and hotels are the primary places today for coming together and sharing. Spaces we pass through but which we do not hesitate to call our own, even if we cross them only once in our lives. Like a restaurant or café where the furnishings enhance the experience, welcoming us for a quick stop or relaxing break. Like a hotel which feels at once like home and part of a new city. Hospitality environments require versatile, cross-cutting furnishings capable of combining practicality and aesthetic sense, a complex task that MDF Italia responds to through design.

IT L'ospitalità è una questione di contesto e di atmosfera: due concetti che abbiamo esplorato a lungo nell'ambito domestico, e oggi traduciamo in chiave contract. Ristoranti, caffè e hotel sono tra i principali luoghi di aggregazione e condivisione della contemporaneità. Spazi di passaggio che non rinunciamo a sentire nostri, anche se li attraversiamo una sola volta nella vita. Come un ristorante o un caffè dove gli arredi valorizzano l'esperienza, accogliendoci per un passaggio veloce o una pausa rilassata. Come un hotel nel quale sentirci allo stesso tempo a casa e parte di una nuova città. Gli ambienti dell'ospitalità richiedono soluzioni d'arredo versatili e trasversali, capaci di coniugare praticità e senso estetico; una complessità a cui MDF Italia risponde usando il design.

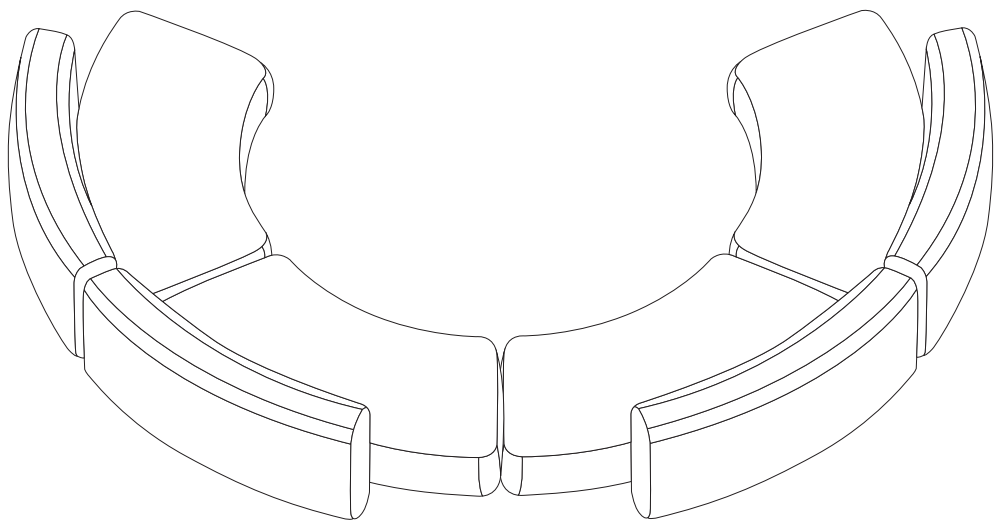

L
Lobby

R+C
Restaurant and Café

H
Hallway

SG
Superior Guestroom

ES
Executive Suite

RT
Rooftop



The environment that welcomes guests is elegant and generous. An almost monumental space, but furnished with essential products. The expressiveness of MDF Italia is reinterpreted in a more classical, discrete key, creating a soft, refined environment.

L'ambiente che accoglie l'ospite è elegante e generoso. Uno spazio quasi monumentale, ma arredato con prodotti essenziali. L'espressività di MDF Italia è reinterpretata in chiave più classica e discreta, per creare un ambiente raffinato e morbido.



Lobby

R·C

H

SG

ES

RT



Cosy Curve



Metodo





Divide IT



Flow Low Table



Yale X sofa and armchair



Minima 3.0 Room Divider





EN Honourable mention at the 18th ADI Compasso d'Oro in 1998, Minima is an aluminium bookcase system consisting in three key elements — shelf, upright, and container — that can be freely configured. Designed by Bruno Fattorini and featuring light, essential lines, Minima has evolved over the years, becoming a versatile, adaptable furnishing system available in different heights and finishes. It is capable of joining multiple functions, with Room Divider, a room-dividing bookcase to elegantly separate environments, and Sketch, a collection of wall-mounted bookshelves that offer the utmost expressive freedom in all areas of the home.

IT Menzione d'onore al XVIII Compasso d'Oro ADI nel 1998, Minima è un sistema di librerie in alluminio composto da tre elementi cardine – mensola, montante, contenitore – che possono essere configurati liberamente. Disegnata da Bruno Fattorini e caratterizzata dall'essenzialità e dalla leggerezza delle linee, Minima nel corso dei decenni si è evoluta, trasformandosi in un sistema d'arredo versatile e adattabile, disponibile in diverse altezze e finiture e capace di unire più funzioni, tra cui quella di Room Divider, una libreria divisoria a centro stanza per separare gli ambienti in modo elegante, e Sketch, una collezione di librerie pensili che offre la massima libertà espressiva in tutte le aree della casa.

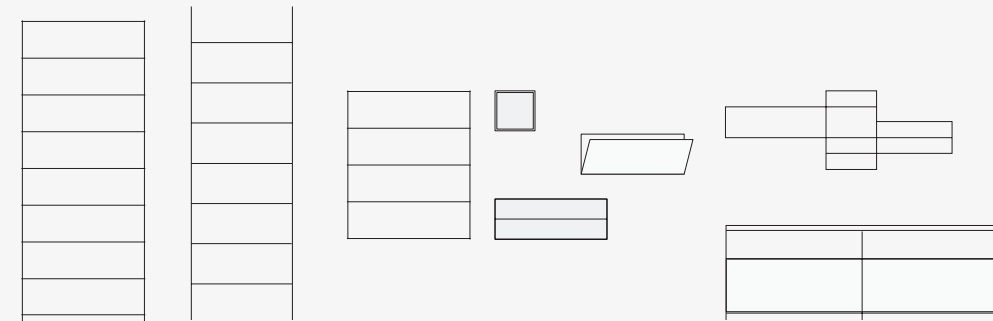

Nella versione room Divider, Minima si presta come libreria divisoria a centro stanza per separare gli ambienti.

In the Room Divider version, Minima lends itself as a room divider bookcase to separate environments.

XVIII
Compasso d'Oro
ADI, Special Mention

Discover
Minima
collection



Minima collection

by Metrica Design Bruno Fattorini

Un sistema versatile realizzato in alluminio 100% riciclabile in quattro diverse finiture.

A versatile system made of 100% recyclable aluminium in four different finishes.

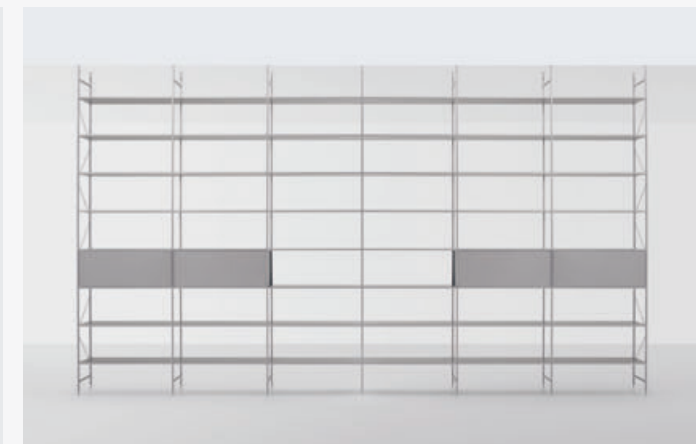
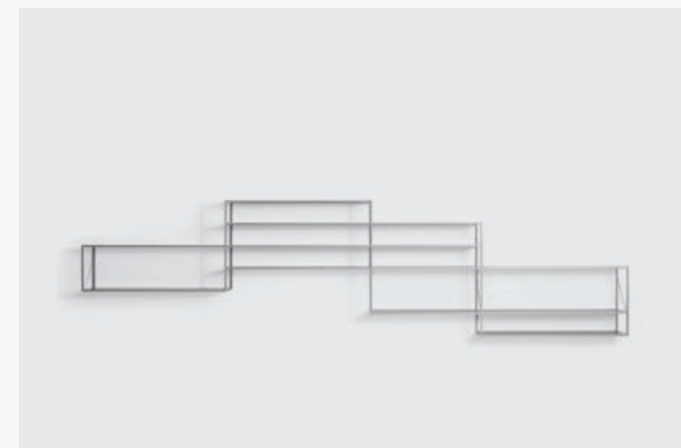
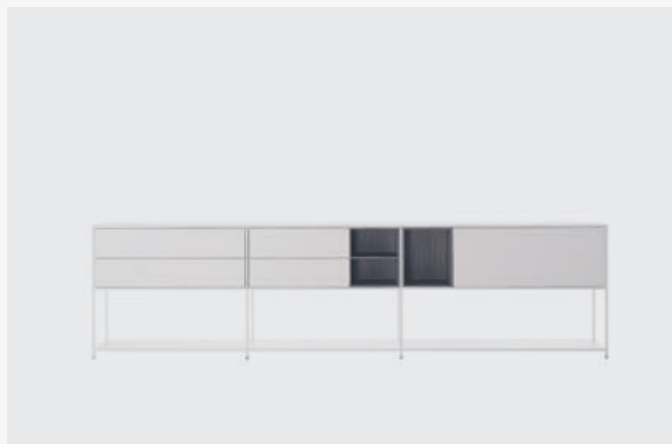



Restaurants and cafés are fluid spaces in the city, open even to people not staying in the hotel. The selection of furnishings expresses a more fluid, informal idea of hospitality for a space that is attractive to different types of customers at different times of the day and at different times of the year.

Il ristorante e la caffetteria sono spazi osmotici rispetto alla città, aperti anche a chi non risiede nell'hotel. La selezione di arredi esprime un'idea di ospitalità più fluida e informale, per uno spazio che diventa attrattivo per clienti di diversa tipologia, in vari momenti del giorno e nei diversi periodi dell'anno.

R+C^L
Restaurant and Café



Universal chair



Tense collection

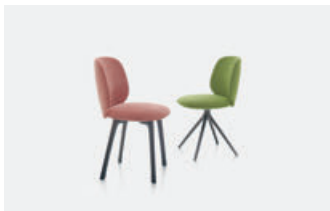

Universal chair



Tense collection



Universal armchair



NVL Table

FOCUS ON

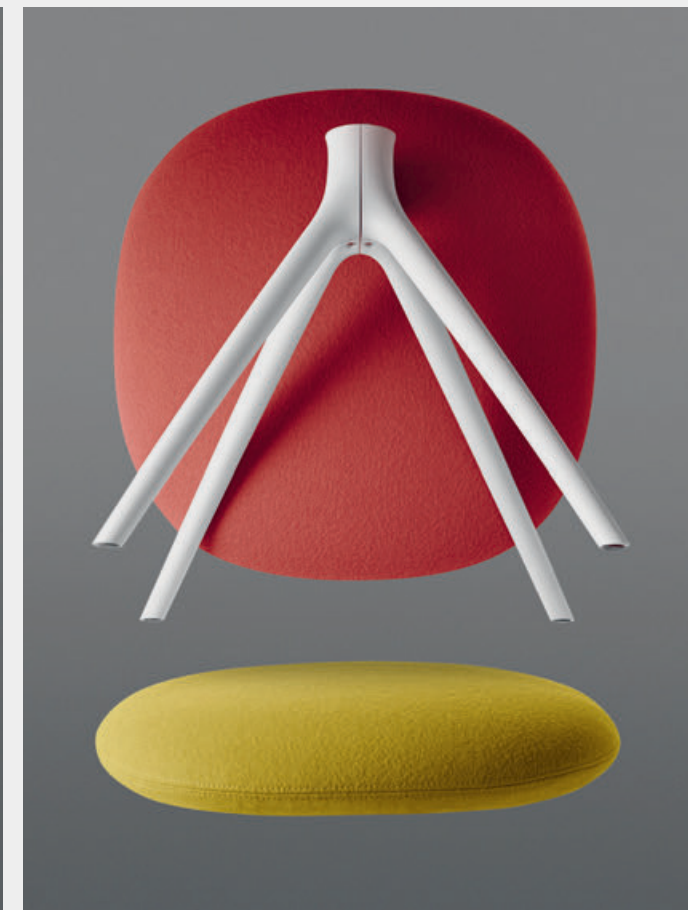
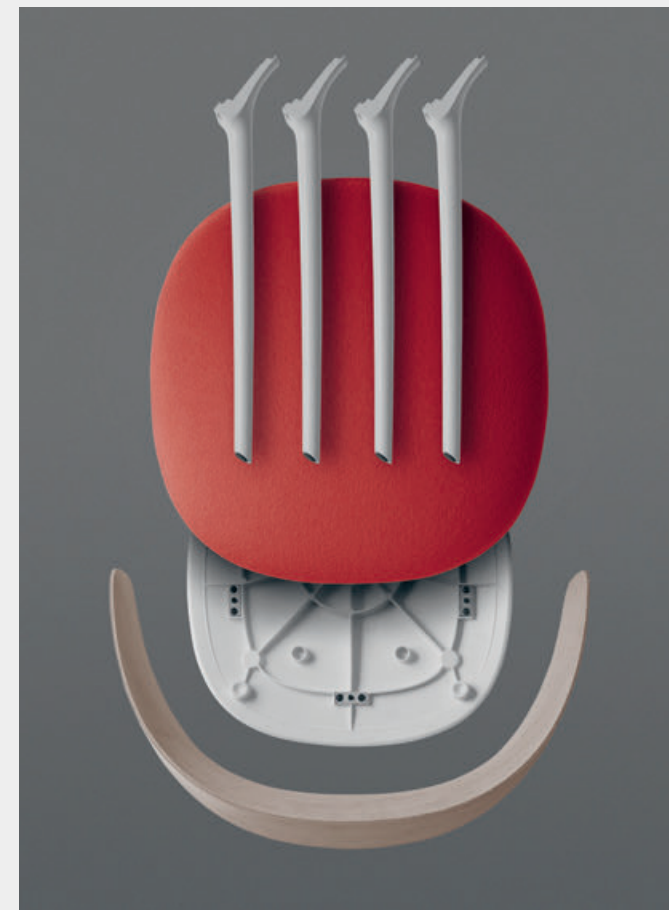
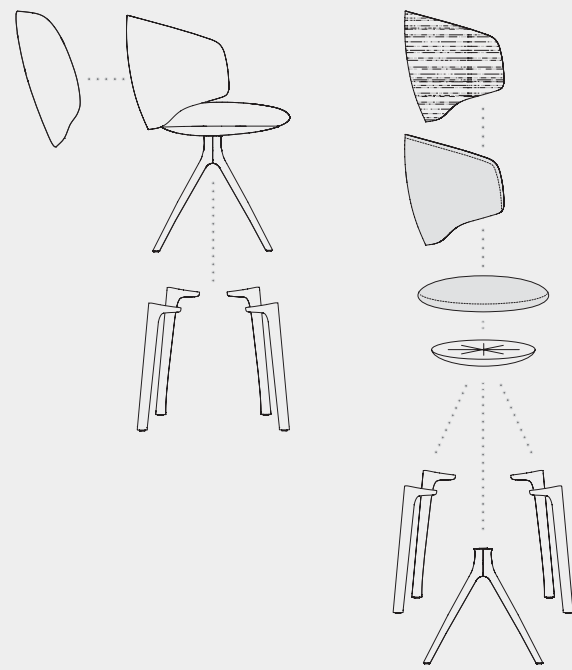

Universal collection

La collezione Universal è connotata per un'impeccabile eleganza delle linee e la straordinaria ergonomia.

Universal collection features impeccable elegance of line and extraordinary ergonomics.

Designed by Jean Marie Massaud

La seduta declinata nella versione sedia o poltroncina con schienale in legno o completamente imbottita, fa dello schienale tridimensionale il suo punto di forza.

In the chair and armchair with wooden backrest or fully upholstered, the three-dimensional back is the focal point of the seating.

Coupled and assembled, with a procedure that echoes the refined savoir-faire of a luthier. A wooden backrest with two curved elements pressed from a mechanical mould.



Bases

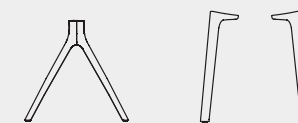

Wooden backrest



Fabrics upholstered backrest

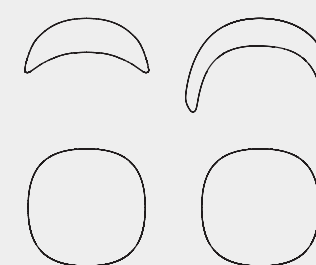



EN Universal is a family of chairs designed by Jean Marie Massaud that features a blend of elegant lines and excellent ergonomics. Based on patented wood-bending technology, Universal owes its name to the plate of the seat, the beating heart of the object. This is designed to support different types of bases or backrests, thus allowing for infinite configurations over time, due as well to the multiple textile combinations. The extreme versatility of the collection means it can be inserted in an original way in the most varied settings, from the home to professional contracts, in a classical or contemporary style.

IT Universal è la famiglia di sedute progettata da Jean Marie Massaud e caratterizzata dalla fusione tra linee eleganti ed ergonomia eccellente. Sviluppata a partire da una tecnologia brevettata sulla curvatura del legno, Universal deve il suo nome al piattello della seduta, cuore pulsante dell'oggetto, predisposto per accogliere diverse tipologie di basamenti e di schienali, permettendo così di sviluppare nel tempo infinite possibilità di configurazioni, grazie anche alle molteplici combinazioni tessili. L'estrema versatilità della collezione le consente di inserirsi in modo originale nei contesti più svariati, dal residenziale al contract, in ambienti dallo stile classico o contemporaneo.

More than 100 fabrics available for infinite configurations.

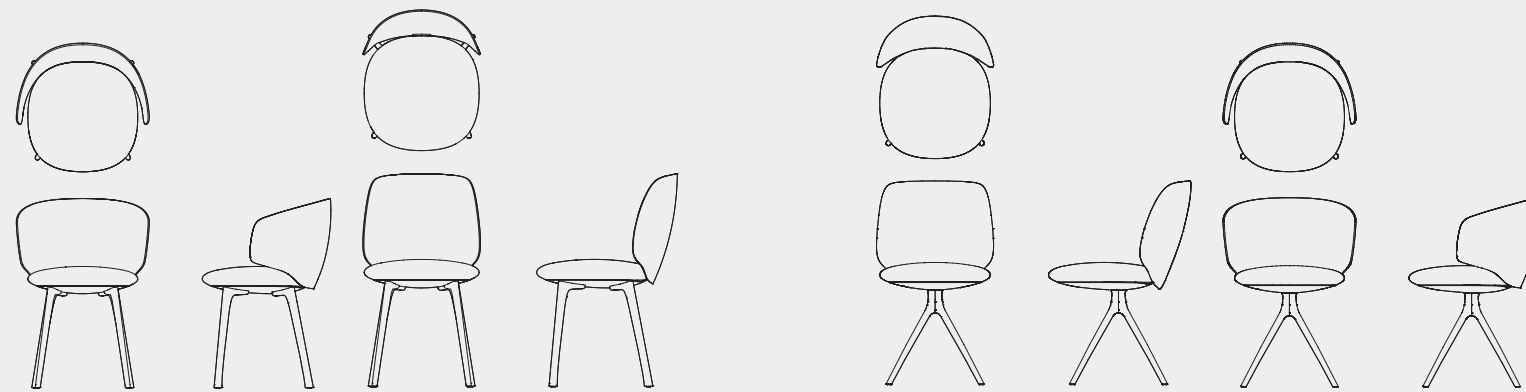

Discover Universal collection



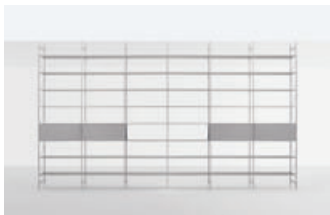

Minima 3.0 Room Divider



Neil Leather stool



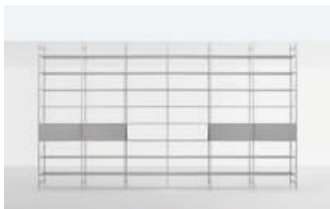

Minima 3.0 Room Divider



Yale X armchair



Neil Leather chair



NVL Table

FOCUS ON

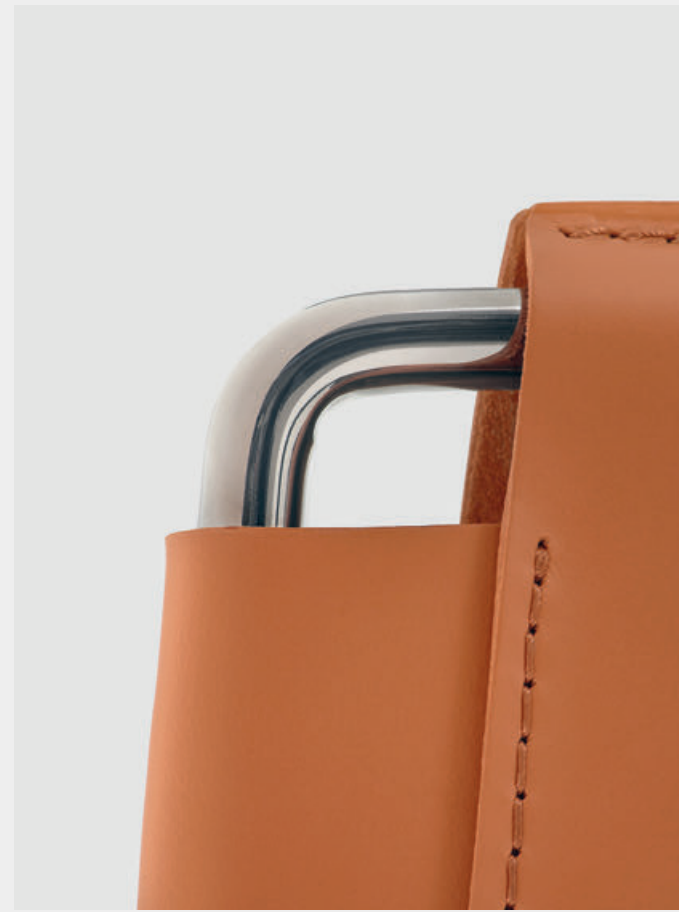
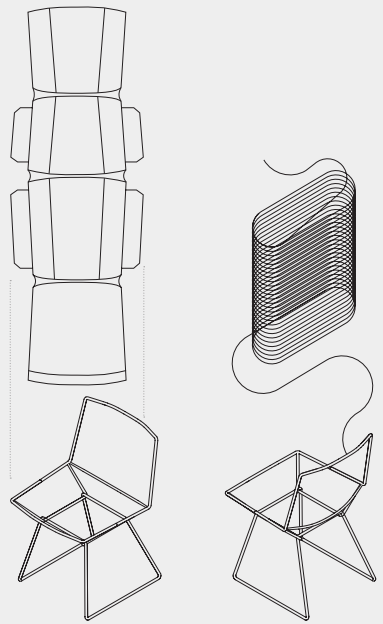

EN Created in 2018, the Neil family of chairs designed by Jean Marie Massaud is a project undergoing continuous development, which is marked by its essential nature, versatility, and careful design. The wire structure marks a simple, light architecture, while the leather, cord, or fabric upholstery, combined with the wide colour range, give it character and allow it to adapt to different indoor and outdoor environments, both residential and professional, depending on the specific needs. Products in the Neil collection, which include chairs and stools, have a sustainable core. Made with high-quality materials and smart production systems, they limit waste, last over time, and can be easily disassembled and recycled at their end of life.

IT Nata nel 2018, la famiglia di sedute Neil disegnata da Jean Marie Massaud è un progetto in continuo sviluppo, che si distingue per essenzialità, versatilità e accuratezza di progettazione. La struttura in filo d'acciaio disegna un'architettura semplice e leggera, mentre il rivestimento in cuoio, corda o tessuto, unito all'ampia gamma cromatica, le dona carattere, permettendole di adattarsi a diversi ambienti, indoor e outdoor, residenziali e contract, a seconda delle esigenze. I prodotti della collezione Neil, che includono sedie e sgabelli, hanno un animo sostenibile: realizzati con materiali di qualità e sistemi di produzione intelligenti, limitano gli sprechi, durano nel tempo e a fine vita possono essere facilmente smontati e riciclati.

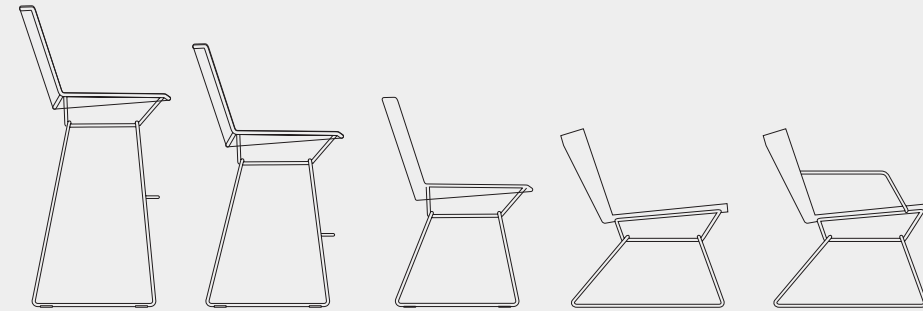

Neil collection

Designed by Jean Marie Massaud

La collezione Neil risponde con eleganza e leggerezza alle esigenze indoor e outdoor, combinando design iconico, essenzialità e comfort.

The Neil collection responds both to outdoor and indoor needs with elegance and lightness, combining iconic design, essentiality and comfort.

Una famiglia declinata nella versione poltroncina, sedia e sgabello in due altezze.

A family available in armchair, chair and stool versions in two heights.

Discover Neil collection

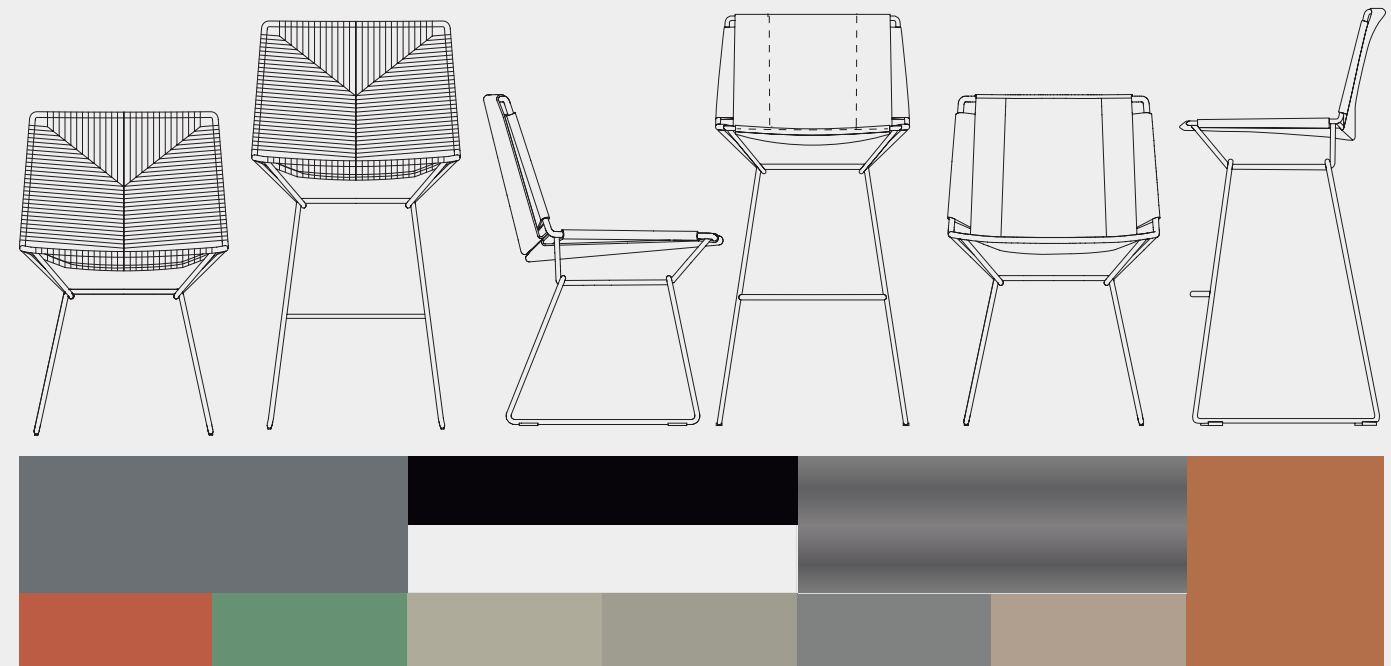



All environments are connected, designed to be occupied in continuity. Hallways stop being an impersonal service space and are harmonized, even aesthetically, with other spaces in the hotel. Just a few elements are needed to characterize them: a bookcase, comfortable armchair, and small table.

Tutti gli ambienti sono connessi tra loro, pensati per essere vissuti in continuità. Il corridoio smette di essere uno spazio di servizio impersonale e si armonizza, anche dal punto di vista estetico, con gli altri spazi dell'hotel. Per caratterizzarlo bastano pochi elementi: una libreria, una poltrona confortevole, un tavolino.

L

R·C



Hallway

SG

ES

RT



Flow Low Table

93



Mia armchair

MDF Italia



Random

Contract book

FOCUS ON

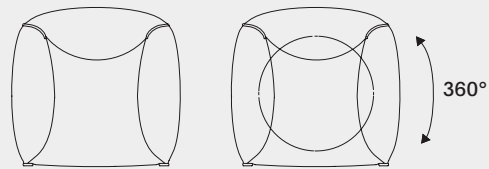

Mia

Designed by Francesco Bettoni

La collezione è caratterizzata da un profilo estetico a forte spessore, in abbinamento al rivestimento o in contrasto.

Mia collection is characterized by a strong character enhanced by its tone-on-tone or contrasting trim.



EN Compact, soft, and welcoming, Mia is a collection consisting of armchairs, sofas, and poufs featuring a thick profile with matching or contrasting upholstery. Designed by Francesco Bettoni, Mia grew out of the simple gesture of folding a cushion and creating a haven for moments of relaxation. The armchair is available in the fixed and in a 360° returning swivel base, while there are three small-sized sofas suitable for any context.

IT Compatta, morbida e accogliente, Mia è una collezione composta da poltrona, divani e pouf caratterizzati da un profilo estetico a forte spessore, in abbinamento al rivestimento o a contrasto. Progettata da Francesco Bettoni, Mia nasce dal semplice gesto di piegare un cuscino e creare un rifugio per i momenti di relax. La poltrona è disponibile nella versione fissa o nella versione girevole a 360° con meccanismo di ritorno, mentre i divani sono tre imbottiti dalle dimensioni contenute, adatti a ogni contesto.



La poltrona Mia è disponibile nella versione fissa o nella versione girevole a 360° con meccanismo di ritorno.

Mia armchair is available with a fixed or with a 360° returning swivel base.

Discover Mia Collection





The heart of a hotel is its rooms. In the Superior Guestroom, the composition leans towards the essentials. In addition to the comfortable bed, an area dedicated to reading and relaxation stands out, as does another dedicated to work, equipped with a desk and small armchair.

Il cuore di un hotel sono le sue camere da letto. Nella Superior Guestroom, la composizione privilegia l'essenzialità: oltre al letto comodo e confortevole, spiccano un'area dedicata alla lettura e al relax e uno spazio di lavoro, attrezzato con scrittoio e poltroncina.

L

R·C

H

SG^H
Superior Guestroom

ES



Flow Low Table



Mia armchair

RT



Achille armchair



Mamba Light



Cosy bed



Flow Low Table



The executive suite is designed for the utmost comfort and privacy. The sleeping area, delimited by micro-architecture with an essential appearance, opens into a larger lounge area that recalls home living, while the corner consisting of desk and chair becomes the perfect workplace.

L'executive suite è pensata per il massimo comfort e la privacy. Lo spazio del letto, delimitato da una micro-architettura dall'estetica essenziale, si apre su un'area lounge più ampia, che evoca il living domestico, mentre la postazione costituita da scrittoio e sedia diventa il perfetto spazio di lavoro.

L

R·C

H

SG

ES
Executive Suite



Aluminium bed



Metodo

RT



Cosy



Yale Low Table



Fuji



Flow Slim



20.Venti Home Light



Aluminium bed



Outdoor inspiration is the key to interpreting new spaces tied to the world of hospitality, such as the rooftop. In harmony with other hotel areas, the space on the top floor both interacts with the city in the background and opens onto it.

L'ispirazione outdoor è la chiave per interpretare i nuovi spazi legati al mondo dell'hôtellerie, come il rooftop. In armonia con gli altri ambienti dell'hotel, il locale all'ultimo piano è allo stesso tempo in dialogo con la città che fa da sfondo e verso cui si apre.

L

R C

H

SG

ES



Neil Twist stool



Rock Table

RT
Rooftop



Arpa

106



Arpa Pouf

Rooftop

Hospitality

107

MDF Italia



Arpa low table

Contract book



Neil Twist armchair

FOCUS ON



EN Harmonious and refined like the musical instrument that lends it its name, Arpa is a furnishing system that allows infinite combinations to be created using different elements: sofas, armchairs, and corner modules. The collection was designed by Ramón Esteve via a rigorous exercise in synthesis, which resolves each piece with the fewest possible number of elements. Arpa combines the stability of the external orthogonal structure with the comfort and softness of the interior cushion. The refined cords add elegance and delicacy to each element, providing a feeling of lightness, as if the upholstery were floating above the structure. The pouf and coffee table complete the collection.

IT Armonioso e raffinato come lo strumento musicale da cui prende il nome, Arpa è un sistema d'arredo che offre la possibilità di creare infinite combinazioni grazie ai diversi elementi a disposizione: divani, poltrone, e moduli angolari. La collezione è stata disegnata da Ramón Esteve tramite un rigoroso esercizio di sintesi, che risolve ogni pezzo con il minor numero possibile di elementi. Arpa combina la stabilità della struttura ortogonale esterna con il comfort e la morbidezza del cuscino interno. Le raffinate corde aggiungono eleganza e delicatezza a ogni elemento della famiglia, donando una sensazione di leggerezza, come se l'intero rivestimento galleggiasse rispetto alla sua struttura. Completano la collezione il pouf e il tavolino.

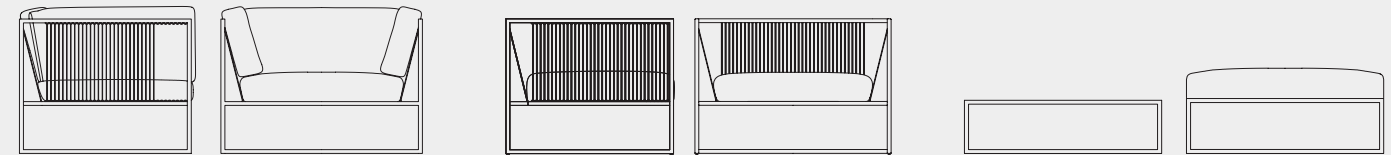

Arpa collection

Designed by Ramón Esteve Estudio

I vari moduli a disposizione, con e senza braccioli, danno vita a diverse configurazioni.

The different available modules, with and without armrests, create different configurations.

Arpa con ampia seduta imbottita e cuscini opzionali per lo schienale, da posizionare liberamente per offrire comfort e allo stesso tempo lasciare visibile il dettaglio dell'intreccio.

Arpa with a large upholstered seat and optional back cushions, which can be positioned freely to provide comfort and at the same time leave the weave detail visible.

Discover Arpa collection



EN Even if the means of working and characteristics of hospitality are changing in time and space, the expressive value of MDF Italia is recognized everywhere. In what follows, we provide a selection of the best projects around the world created with our furnishings.

IT Anche se le modalità di lavoro e le caratteristiche dell'ospitalità cambiano nel tempo e nello spazio, i valori espressivi di MDF Italia sono riconosciuti universalmente. A seguire, una selezione dei migliori progetti realizzati con i nostri arredi nel mondo.



- Luxottica HQ¹
- Amplifon HQ²
- Unicredit International Center³
- Campari HQ⁴
- Kellerhals Carrard Studio⁵
- Petronas HQ⁶
- EDP HQ⁷
- On Running HQ⁸



Airbnb Design Experience¹
Château de la Barbinière²
Hotel H10 Art Gallery³
Palazzo Vendramin Costa⁴
Kuramathi Island Resort⁵
Viva Restaurant⁶
Herzig Restaurant⁷
Ristorante Tamo⁸



2

3

5

8

References

A

2 Verandas Private House ^(R)
3540 Creeky Avenue ^(R)
3K Hotel ^(H)
90° Café Bar Lounge ^(H)
Aberdeen ^(H)
Academy of Fine Arts ^(H)
Agalarou Private House ^(R)
Agos Ducato Milano ^(O)
Airbnb ^(H)
ALD Office ^(O)
Alitalia Lounge Dolce Vita,
Fiumicino International Airport ^(H)
Amalgamation of Styles ^(O)
Amazon ^(O)
Amplifon HQ ^(O)
Aon ^(O)
Apple ^(O)
Aqua Blue Private House ^(R)
Arc Wattripont Private House ^(R)
Arrow Tankers Office ^(O)
Ascendis Pharma Office ^(O)
Askeland Byggmester Office ^(O)
Assassino Restaurant ^(H)
Associate Office ^(O)
ASSOS of Switzerland SA Office ^(O)
Aston Martin ^(O)
Audi ^(O)
Audley Court ^(R)
AUM Head Office ^(O)
Axa ^(O)
Azzurra Restaurant ^(H)
Azzurro Wellness ^(H)

B

B Private House ^(R)
Bacardi ^(O)
Baked by the Heat Private House ^(R)
Balo Private House ^(R)
Banca Popolare di Sondrio ^(O)
Basix Office ^(O)
Beirut Private House ^(R)
Belgian Church Office ^(O)
Benetton ^(O)
Boggi Headquarter ^(O)
Breeze Private House ^(R)
Brescia Private House ^(R)
Brookville Road Private House ^(R)
Bticino Private automation House ^(R)
Bulthaup Shop ^(O)
Bureau Tecclem Office ^(O)

C

Campari Headquarter ^(O)
Cartier ^(O)
Castiglion Fiorentino Private House ^(R)
Cavalli ^(O)
Cepovett Headquarter ^(O)
Chanel ^(O)
Château de la Barbinière ^(H)
Chicago Private House ^(R)
China City Pavilion, Expo 2015 ^(H)
CHP Legal Office ^(O)
Chromavis ^(O)
CK Private House ^(R)
Club Med ^(H)
Cocinas O'Donnel Bulthaup Office ^(O)
Community Rucphen ^(H)
Cook & Book ^(H)
Cooperate Cosmetics ^(H)
Cooperate English First ^(O)
Cose di Casa Private House ^(R)
Costume National ^(H)
Cozy Living ^(R)
Cracow Apartment ^(R)
Credit Agricol ^(O)
Cynoit NV Office Loft ^(O)
Czech Republic Private House ^(R)

D

Delft Jewellery ^(O)
Deloitte Office ^(O)
Delft Private House ^(R)
Design Office ^(O)
Dolce & Gabbana ^(O)
Dordrechts Museum ^(H)
DR Private House ^(R)
Dragao Stadium ^(H)
Duty Free Shop ^(O)

Selected list

E

EDP Headquarter ^(O)
Electric Company Restyling ^(O)
Elitis Showroom ^(O)
Enel ^(O)
Engadina Private House ^(R)
Enjoy Arena ^(O)
Eos e Studio Fumagalli &
Codega Office ^(O)
ePrice ^(O)
Equip Hotel ^(H)
Ernest & Young ^(O)
Euroristoro HQ ^(O)
Expo San Pellegrino ^(H)

F

Facebook ^(O)
Fairfax Road ^(R)
Fameccanica ^(O)
Faroe Island Private House ^(R)
Feather Private House ^(R)
Ferretti Group ^(O)
Fitzroy Private House ^(R)
Flash Art Vip Lounge ^(H)
Fletcher Hotel ^(H)
Fraber Office ^(O)

G

Garage 45 Restaurant ^(H)
GDF Suez Electrabel,
North Light Building ^(H)
Gentofte SØ Private House ^(R)
Golf Private House ^(R)
Gomma Gomma HQ ^(O)
Google Dolce Vita HQ ^(O)
Graffiti Café ^(H)
Grans Viles ^(R)
Groupama ^(O)
Gucci ^(O)

H

H_Apartment ^(R)
H10 Art Gallery Hotel ^(H)
Hamapharm Headquarter ^(O)
Hawthorn East Private House ^(R)
Henry Street Private House ^(R)
Hermes ^(O)
Herzig Restaurant Vienna ^(H)
Hilton Hotel ^(H)
Home Design Showroom ^(H)
Hossegor Private House ^(R)
Hotel Dulac Riva Del Garda ^(O)
Hotel Lutera Paris ^(O)
Houston Residence ^(R)

I

Ibis Hotels ^(H)
Ibla Resort ^(H)
Iceberg ^(O)
IDFM Meda ^(O)
IG&H ^(O)
Inail ^(O)
Industria Restaurant ^(H)

J

Jasper Hotel ^(H)
Juncos Redondo Arquitectos ^(O)

K

Keerbergen Private House ^(R)
Kellerhals Carrard HQ ^(O)
Kitchen Fukuoka Private House ^(R)
Koeln Messe Office ^(O)
Krizia ^(O)
Kruisherer Hotel ^(H)
Kuramathi Island Resort ^(H)

L

L_Apartment ^(R)
La Gare Venezia ^(O)
LA Private House ^(R)
La Torre ^(H)
Lancome ^(O)
Lawyer Office ^(O)
Lemoine Private House ^(R)
Leo Burnet ^(O)
Lexmar Nutricia ^(H)
LG Hi Macs ^(O)
Liberty Private House ^(R)

(H) Hospitality
(O) Office
(R) Residential

Light Design @ Home 2010 ^(H)

Linkedin ^(O)
Literal Restaurant ^(H)
Lotus Motorshow Paris 2010 ^(H)
Loyens en Loeff ^(H)
Lugano Private House ^(R)
Lurago Marinone Private House ^(R)
Luxottica Milano ^(O)

M

M_Apartment ^(R)
M&AH Private House ^(R)
MA Private House ^(R)
Mac'do Orly Paris ^(H)
Macau Private House ^(R)
Maha Bin Hendi Law Firm Office ^(O)
Manoir Restaurant ^(H)
Mc Donald's ^(O)
Medi Bank ^(O)
Mediathek ^(H)
Microsoft ^(O)
Miele Office ^(O)
Miromesnil Paris Private House ^(R)
Molino Restaurant ^(H)
Morgan Mc Kinley ^(H)
Mr Peng's Private House ^(R)
Ms Qian Private House ^(R)
Multi Unit Private House ^(R)
Munte Private House ^(R)
Museum du Louvre ^(H)
Mykonian Korali Hotel ^(H)

N

Nat Private House ^(R)
Netlog ^(O)
New Babylon Toren HQ ^(O)
NH Hotel ^(H)
Nike ^(O)
Norway Chalet ^(R)
Norway Project ^(O)
Novartis Campus ^(O)
Nuon Office ^(O)

O

Ocean Private House ^(R)
Open Kitchen & Living Room ^(R)
Oslo Private House ^(R)

P

Parc Broekhuizen Hotel ^(H)
Parioli Apartment ^(R)
Partyrent Headquarter ^(O)
Pastor Real Estate ^(O)
PDO Private House ^(R)
Penthouse 68 ^(R)
Petronas ^(O)
Pharma.be ^(O)
Philip Morris ^(O)
Philips ^(O)
Plan Effect Office ^(O)
Pompidou ^(H)
Poolhouse Marke ^(R)
Porsche Norway ^(O)
Porta Venezia Apartment ^(R)
Presidio VC Offices ^(O)
Prima Penthouse ^(R)
ProSieben Sat1 Media AG ^(H)
Puma HQ ^(O)
Pure Hotel ^(H)

R

Ramat Private House ^(R)
Ramstein-Optik AG ^(H)
Rao Private House ^(R)
Renault ^(O)
Reply ^(O)
RH Residence ^(R)
Rhode St Genese Private House ^(R)
Riboli Private House ^(R)
Rini Private House ^(R)
RMIT Law Library ^(O)
Roche ^(O)
Rolex ^(O)
Rothschild Office ^(O)
RSI ^(O)

S

S_12 Private House ^(R)
Safehouse Oakley ^(H)
Saffron Restaurant ^(H)
St.Petersburg Private House ^(R)
Salle des Mariages Villeneuve
lez Avignon ^(H)
Samsonite ^(O)
Samsung's National Commercial
Campaign ^(H)
San Carlo Private House ^(R)
San Paolo Company ^(O)
Sandnes Private House ^(R)
Sani Private House ^(R)
SDV View Apartment ^(R)
Singapore Private House ^(R)
Sky ^(O)
SL Private House ^(R)
Slattery Auction ^(O)
SM Private House ^(R)
Sme Up Ebrusco ^(O)
Sorrento Private House ^(R)
Split Level Loft ^(R)
Springvale Cemetary ^(H)
Stonefly ^(H)
Strenesse ^(H)
Stud Farm ^(R)
Summer Private House ^(R)
Swarovsky ^(O)
SWFC Building Office ^(O)
Swiss & Globa Asset Mgmt AG ^(O)
Swisscom ^(O)

T

Tamo Restaurant ^(H)
Telecom Italia Headquarter ^(O)
Teo Jakob Baar ^(H)
Têtedoie Restaurant ^(H)
Tetrac ^(O)
The Englefield Private House ^(R)
The Wall House ^(R)
TLV Private House ^(R)
Tokyo International Airport,
Terminal 2 – Food Court ^(H)
Torhout Private House ^(R)
Torino Legal Office ^(O)
Townhouse Duomo Hotel ^(H)
Toyota Showroom ^(H)
TP Office ^(O)
Traiteur Dangelmann New Babylon ^(H)
Télévision Suisse Romande ^(H)

U

Uber Company ^(O)
Uberaba Private House ^(R)
Uccle Private House ^(R)
Ugolini Pavia ^(O)
Umicore ^(O)
Unicredit International Center ^(O)
Unione Fiduciaria HQ ^(O)

V

Vamnous Restaurant,
Olympiacos Stadium ^(H)
Varsavia Private House ^(R)
Väth E.V. Berlin Office ^(O)
VM Altamura Private House ^(R)

W

W.I.N.D. Private House ^(R)
Who*Who Showroom Milano ^(H)
Wireless Private House ^(R)
W.Horizon Private House ^(R)

X

XAL GmbH ^(O)
Xantippe ^(H)

Y

Youtube ^(O)

Z

Zarzo Restaurant ^(H)
Zheng's Private House ^(R)
Zoetelief Restaurant ^(H)
Zone Hotel ^(H)

Tools and awards

Certifications



The mark of
responsible forestry



Products configurator

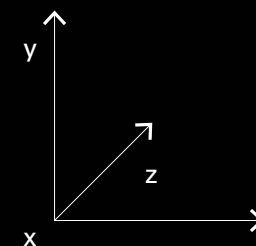

Discover
the configurator

Awards





The collaboration between MDF Italia and 967arch was born from a stylistic affinity, from an approach to product and project design that found a natural meeting point. First in the use of MDF Italia collections in contract projects developed by the Milanese studio and then in the recognition of 967arch's architectural projects as the identity of a precise design philosophy. This led to the request to develop an ad-hoc project for the MDF Italia contract office between reality and imagination, product and space. In the perception and rationalisation of a precise and similar creative language, in which the catalogue becomes the natural expression and completion of the project. The final result is a story, a journey through the various environments that compose the workspaces, from the most consolidated to the most creative and open to contamination from other sectors.

La collaborazione tra MDF Italia e 967arch nasce da un'affinità stilistica, da un approccio al design di prodotto e di progetto che ha trovato un naturale incontro. Dapprima nell'utilizzo delle collezioni di MDF Italia nei progetti di contract sviluppati dallo studio milanese ed in seguito nel riconoscimento dei progetti architettonici di 967arch come identitari di una precisa filosofia progettuale. Così è nata la richiesta di sviluppare un progetto ad hoc per il contract office di MDF Italia tra realtà e immaginazione, tra prodotto e spazio, nella percezione e razionalizzazione di un preciso ed affine linguaggio creativo, in cui il catalogo diventa naturale espressione e completamento del progetto. Il risultato è un racconto, un percorso tra i vari ambienti che compongono gli spazi di lavoro, da quelli più consolidati a quelli più creativi ed aperti alle contaminazioni di altri settori.

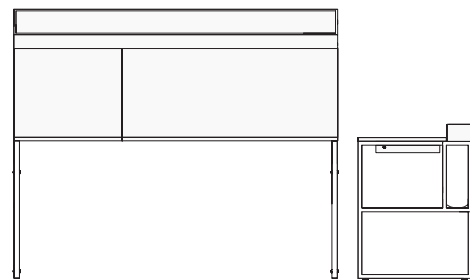

Biography

967arch is a studio in Milan that has worked on architecture, interior design, and product design for more than 20 years. Founded by Cesare Chichi and Stefano Maestri, it combines an artisan approach, from creative workshop to the standards of the managerial production process. The story is central in each project, the logical support for each stylistic and distinctive choice. Simplicity and moderation characterize all their work, combined with irony and attention to detail.

Biografia

967arch è uno studio milanese che da più di vent'anni progetta architettura, interior e product design. Fondato da Cesare Chichi e Stefano Maestri, unisce un approccio artigianale, da bottega creativa, ai canoni del processo produttivo manageriale. In ogni proposta a essere centrale è il racconto, supporto logico a ogni scelta stilistica e d'identità. Semplicità e sobrietà caratterizzano tutti i lavori, unite a ironia e cura dei dettagli.

967

arch

Credits

Graphic design

Studio CCRZ

Contract concept and design

967arch

Photo

Simone Cavadini

Still life Lorenzo Cappellini Baio

Digital images Nudesign

Text

Cosimo Bizzarri

Lisa Cadamuro

MDF Italia Srl Società Unipersonale

Headquarters

Via Fratelli Cervi 4/A

22066 Mariano Comense (CO)

© 2023

MDF Italia all rights reserved

MDF Italia reserves the right to change,

at any time and without prior warning,

the technical specifications of any products

illustrated in this catalogue.

www.mdffitalia.it

contract.mdffitalia.com



Discover the
Contract products

Follow us



mdf italia

